

Model No. NTTL90081

Serial No. _____

Find the serial number in the location shown below. Write the serial number in the space above for reference.

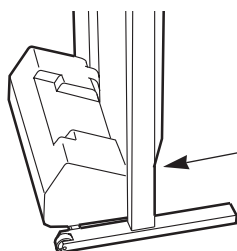

Serial
Number
Decal



1500

Questions?

As a manufacturer, we are committed to providing complete customer satisfaction. If you have questions, or if there are missing or damaged parts, we will guarantee complete satisfaction through direct assistance from our factory.

TO AVOID UNNECESSARY DELAYS, PLEASE CALL DIRECT TO OUR TOLL-FREE CUSTOMER HOT LINE. The trained technicians on our Customer Hot Line will provide immediate assistance, free of charge to you.

CUSTOMER HOT LINE:

1-800-999-3756

Mon.-Fri., 6 a.m.-6 p.m. MST

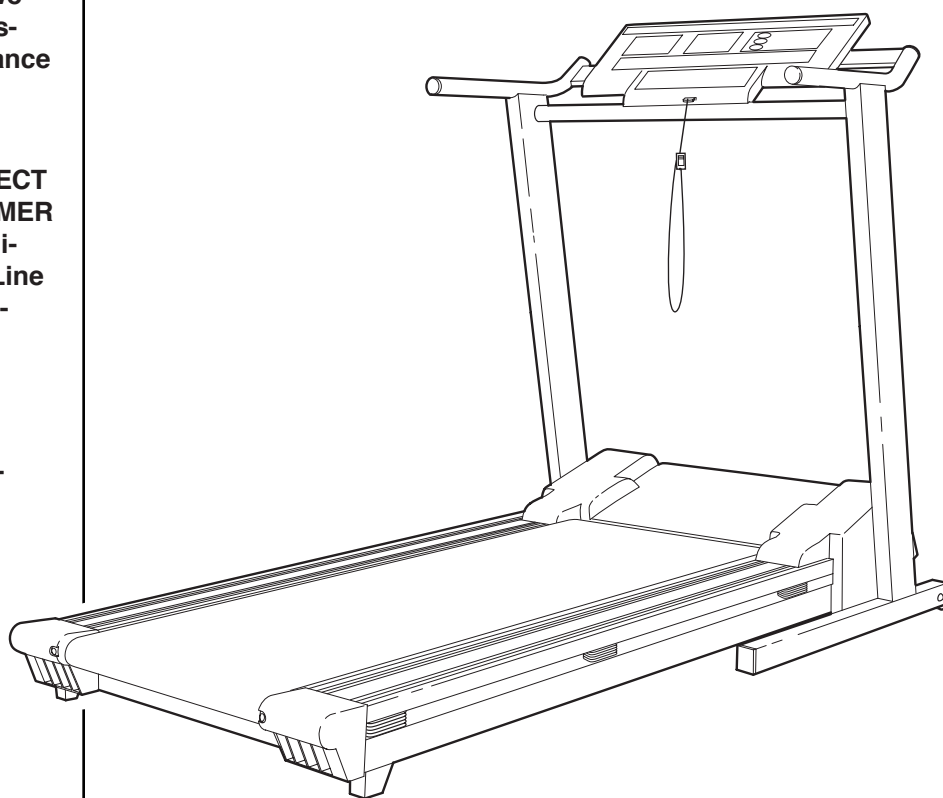

⚠ CAUTION

Read all precautions and instructions in this manual before using this equipment. Save this manual for future reference.

OWNER'S GUIDE



Table of Contents

Important Precautions	3
Before You Begin	5
Assembly	6
Treadmill Operation	7
How to Fold and Move the Treadmill	13
Maintenance and Trouble-shooting	15
Conditioning Guidelines	18
Part List	22
How to Order Replacement Parts	23
Warranty Information	Back Cover

Note: An Exploded Drawing is attached in the center of this owner's guide.

Important Precautions

⚠️ WARNING: To reduce the risk of burns, fire, electric shock, or injury to persons, read the following important precautions and information before operating the treadmill.

1. It is the responsibility of the owner to ensure that all users of this treadmill are adequately informed of all warnings and precautions.
2. Use the treadmill only as described in this owner's guide.
3. Place the treadmill on a level surface, with eight feet of clearance behind it. Do not place the treadmill on any surface that blocks air openings. To protect the floor or carpet from damage, place a mat under the treadmill.
4. Keep the treadmill indoors, away from moisture and dust. Do not put the treadmill in a garage or covered patio, or near water.
5. Do not operate the treadmill where aerosol products are used or where oxygen is being administered.
6. Keep children under the age of 12 and pets away from the treadmill at all times.
7. The treadmill should not be used by persons weighing more than 250 pounds. Never allow more than one person on the treadmill at a time.
8. Wear appropriate clothing when using the treadmill. Do not wear loose clothing that could become caught in the treadmill. Athletic support clothes are recommended for both men and women. Always wear athletic shoes. Never use the treadmill with bare feet, wearing only stockings, or in sandals.
9. When connecting the power cord (see How to Plug in the Power Cord on page 7), plug the power cord into a surge protector (not included) and plug the surge protector into a grounded circuit capable of carrying 15 or more amps. No other appliance should be on the same circuit.
10. Use only a UL-listed surge protector, rated at 15 amps, with a 14-gauge cord of five feet or less in length. Do not use an extension cord.
11. Keep the power cord and the surge protector away from heated surfaces.
12. Never move the walking belt while the power is turned off. Do not operate the treadmill if the power cord or plug is damaged, or if the treadmill is not working properly. (See Before You Begin on page 5 if the treadmill is not working properly.)
13. Never start the treadmill while you are standing on the walking belt. Always hold the handrails while using the treadmill.
14. The treadmill is capable of high speeds. Adjust the speed in small increments to avoid sudden jumps in speed.
15. To reduce the possibility of the treadmill overheating, do not operate the treadmill continuously for longer than one hour.
16. Never leave the treadmill unattended while it is running. Always remove the key, unplug the power cord and move the on/off switch to the off position when the treadmill is not in use. (See the drawing on page 5 for the location of the on/off switch.)
17. Do not attempt to raise, lower, or move the treadmill until it is properly assembled. (See Assembly on page 6, and How to Move the Treadmill on page 13.) You must be able to safely lift 45 pounds (20 kg) in order to raise, lower, or move the treadmill.
18. When folding or moving the treadmill, make sure that the frame is held securely by the storage latch.
19. Inspect and tighten all parts of the treadmill every three months.
20. The roller guards must be 1/8 inch from the rear roller (see the drawing on page 5). Remove the key and adjust the roller guards, if necessary.

21. Never drop or insert any object into any opening.

22. **DANGER:** Always unplug the power cord immediately after use, before cleaning the treadmill, and before performing the maintenance and adjustment procedures described in this manual. Never remove the

motor hood unless instructed to do so by an authorized service representative. Servicing other than the procedures in this manual should be performed by an authorized service representative only.

23. This treadmill is intended for in-home use only. Do not use this treadmill in any commercial, rental, or institutional setting.

⚠ WARNING: Before beginning this or any exercise program, consult your physician. This is especially important for persons over the age of 35 or persons with pre-existing health problems. Read all instructions before using. ICON assumes no responsibility for personal injury or property damage sustained by or through the use of this product.

Save These Instructions

The decals shown below have been placed on your treadmill. If one of the decals is missing, or if it is not legible, please call our Customer Service Department toll-free to order a free replacement decal (see the back cover of this manual). Apply the decal in the location shown.

⚠ ATTENTION

- Gardez les enfants éloignés du tapis roulant en tout temps.
- Veuillez vous assurer que le loquet de rangement est complètement fermé avant de déplacer le tapis roulant ou de le ranger.
- Avis Important: Réglez le degré d'inclinaison au minimum avant de plier le tapis roulant.

⚠ WARNING

- Never allow children to play on or around treadmill.
- Storage latch must be fully engaged before treadmill is moved or stored.
- Important: incline must be set at lowest level before folding treadmill into storage position.

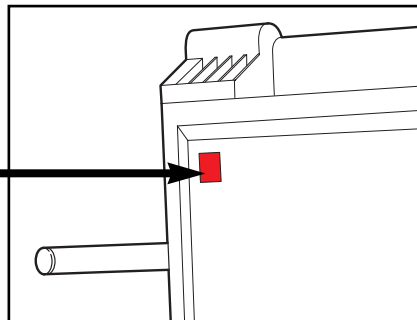

⚠ CAUTION

KEEP HANDS AND FEET AWAY FROM THIS AREA WHILE THE TREADMILL IS IN OPERATION.

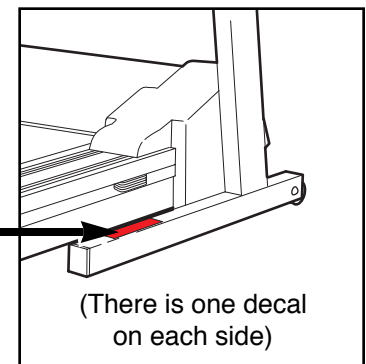

Before You Begin

Thank you for selecting the new NordicTrack PowerTread™ 1500 treadmill. The PowerTread 1500 treadmill combines advanced technology with innovative design to let you enjoy an excellent form of cardiovascular exercise in the convenience and privacy of your home. And when you're not exercising, the unique PowerTread 1500 can be folded up, requiring less than half the floor space of other treadmills.

For your benefit, read this manual carefully before using the treadmill. If you have additional questions, please call our toll-free Customer Service Department

at 1-800-999-3756, Monday through Friday, 6 a.m. until 6 p.m. Mountain Time (excluding holidays). To help us assist you, please note the product model number and serial number before calling. The model number of the treadmill is NTTL90081. The serial number can be found on a decal attached to the treadmill (see the front cover of this manual for the location).

Before reading further, please review the drawing below and familiarize yourself with the parts that are labeled.

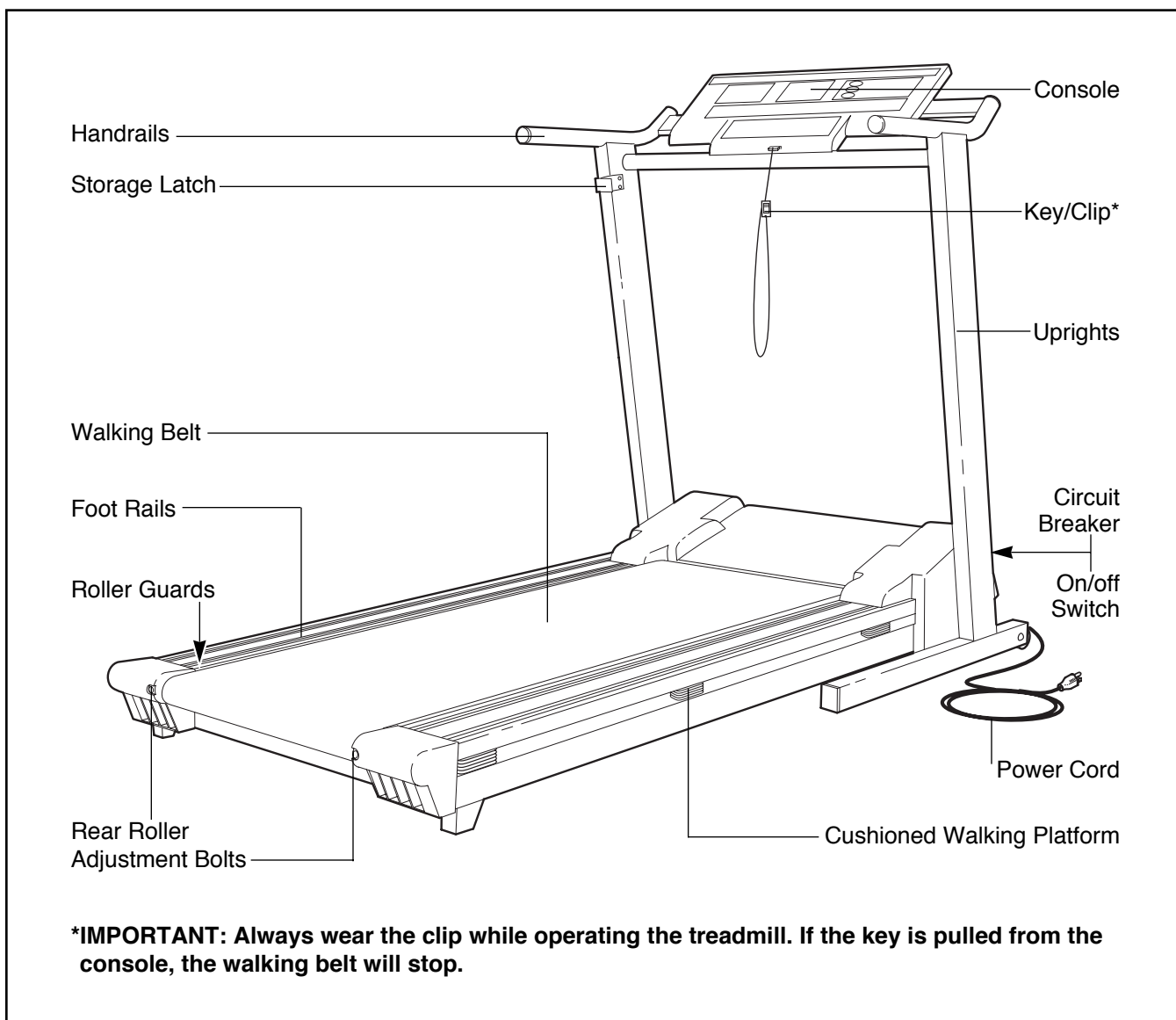

Assembly

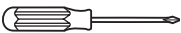
Assembly requires two people. Set the treadmill in a cleared area and remove all packing materials. Assembly requires a phillips screwdriver  (not included).

Note: The walking deck of the treadmill features a coating of high-performance lubricant. During shipping, a small amount of this lubricant may be transferred to the top of the walking belt or shipping carton. This is a normal condition and does not affect treadmill performance. If there is lubricant on top of the walking belt, simply wipe off the lubricant with a soft cloth and a mild, non-abrasive cleaner.

1. With the help of a second person, carefully raise the Uprights (70) until the Wheels (30) are resting flat on the floor.

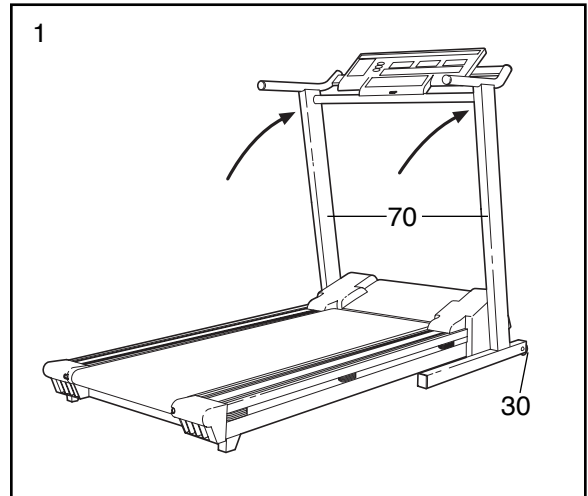

2. Remove the two indicated Screws (43) from the left Upright (70).

Attach the Storage Latch (5) and the two Latch Spacers (93) to the left Upright (70) with the two Screws (43). **Be careful not to overtighten the Screws.**

Note: If it is difficult to fold or lower the treadmill, remove one or both of the Latch Spacers (93).

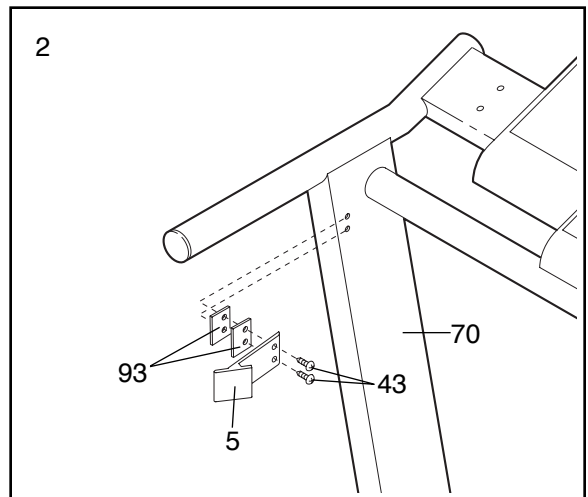

3. Remove the backing from the Wrench Clip (88). Press the Wrench Clip onto the left or right Upright (70) in the indicated location. Press the Allen Wrench (87) into the Wrench Clip.

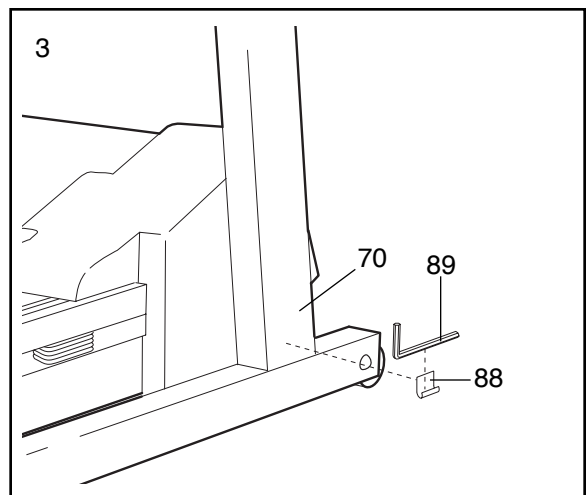

4. **Make sure that all parts of the treadmill are properly tightened.** Place a mat beneath the treadmill to protect the floor or carpet.

Treadmill Operation

THE PERFORMANT LUBE™ WALKING BELT

Your treadmill features a walking belt coated with PERFORMANT LUBE™, a high-performance lubricant. **IMPORTANT: Never apply silicone spray or other substances to the walking belt or the walking platform. They will deteriorate the walking belt and cause excessive wear.**

HOW TO PLUG IN THE POWER CORD

⚠ DANGER: Improper connection of the equipment-grounding conductor can result in an increased risk of electric shock. Check with a qualified electrician or service representative if you are in doubt as to whether the product is properly grounded. Do not modify the plug provided with the product—if it will not fit the outlet, have a proper outlet installed by a qualified electrician.

Your treadmill, like any other type of sophisticated electronic equipment, can be seriously damaged by sudden voltage changes in your home's power. Voltage surges, spikes, and noise interference can result from weather conditions or from other appliances being turned on or off. **To decrease the possibility of your treadmill being damaged, always use a surge protector (not included) with your treadmill.**

Surge protectors are sold at most hardware stores and department stores. Use only a UL-listed surge protector, rated at 15 amps, with a 14-gauge cord of five feet or less in length.

This product must be grounded. If it should malfunction or break down, grounding provides a path of least resistance for electric current to reduce the risk of electric shock.

This product is equipped with a cord having an equipment-grounding conductor and a grounding plug. **Plug the power cord into a surge protector, and plug the surge protector into an appropriate outlet that is properly installed and grounded in accordance with all local codes and ordinances.**

This product is for use on a nominal 120-volt circuit, and has a grounding plug that looks like the plug illustrated in drawing 1 below. A temporary adapter that looks like the adapter illustrated in drawing 2 may be used to connect the surge protector to a 2-pole receptacle as shown in drawing 2 if a properly grounded outlet is not available.

The temporary adapter should be used only until a properly grounded outlet (drawing 1) can be installed by a qualified electrician.

The green-colored rigid ear, lug, or the like extending from the adapter must be connected to a permanent ground such as a properly grounded outlet box cover. Whenever the adapter is used it must be held in place by a metal screw. **Some 2-pole receptacle outlet box covers are not grounded. Contact a qualified electrician to determine if the outlet box cover is grounded before using an adapter.**

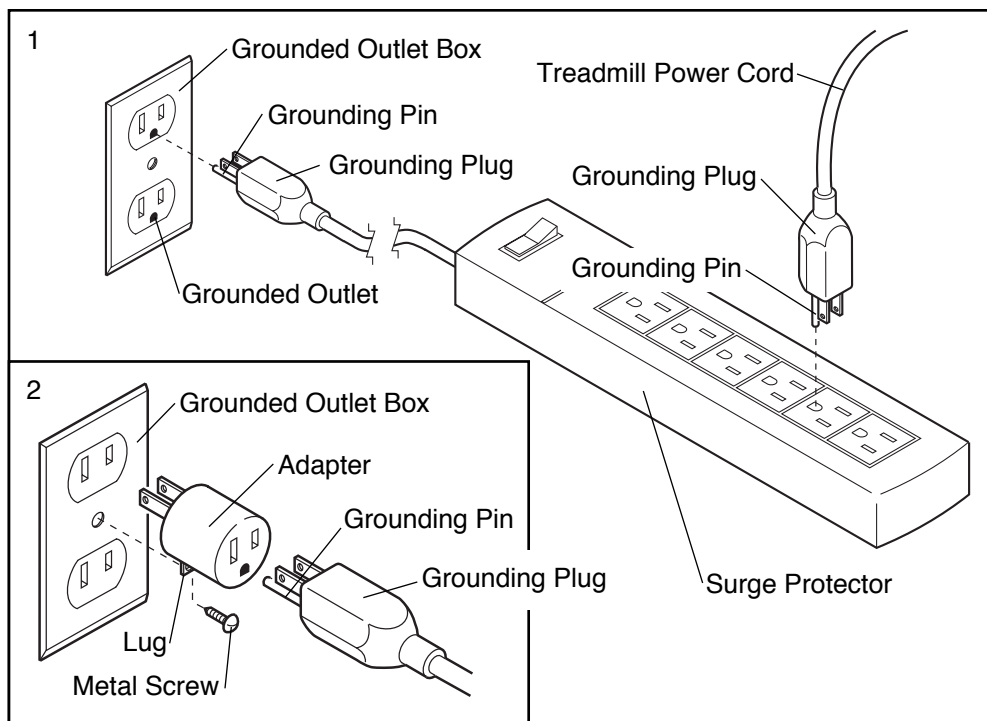
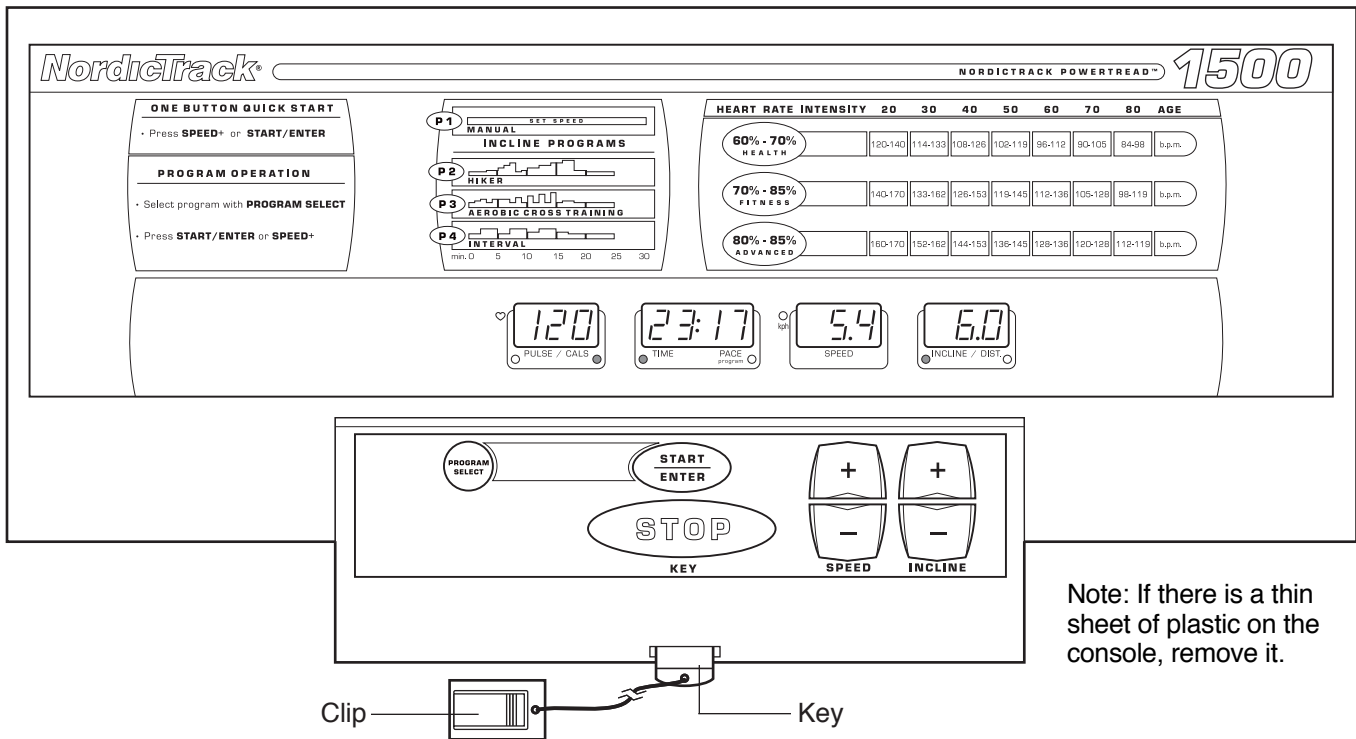

DIAGRAM OF THE CONSOLE



CAUTION: Before operating the console, read the following precautions.

- Do not stand on the walking belt when turning on the power or starting the walking belt.
- Always wear the clip (see the drawing above) while operating the treadmill. If the key is pulled from the console, the walking belt will stop.
- The treadmill is capable of high speeds. Adjust the speed in small increments.
- To reduce the risk of electric shock, keep the console dry. Use only a sealed water bottle.

FEATURES OF THE CONSOLE

The treadmill console offers an impressive array of features designed to make your workouts more effective. When the console is in the manual mode, the speed and incline of the treadmill can be changed with a touch of a button. As you exercise, four displays will provide continuous exercise feedback. In addition, three preset programs will automatically control the incline of the treadmill as they guide you through effective workouts.

To use the MANUAL mode, follow the steps on pages 9 and 10. To use the INCLINE programs, see pages 11 and 12.

Note: The console can display speed and distance in either miles or kilometers (see Speed Display on page 10). For simplicity, all instructions in this owner's guide refer to miles.

HOW TO USE THE MANUAL MODE

1 Plug in the power cord.

Follow the instructions on page 7 to plug in the power cord. When the power cord is plugged in, the displays on the console will flash once. (Note: If the key is in the console when the power cord is plugged in, the letters "PO" will flash in the SPEED display. If this occurs, remove the key.) Next, press the on/off switch on the front of the treadmill to the on position.

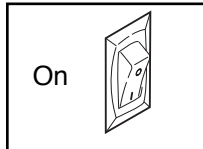

2 Insert the key fully into the console.

Stand on the foot rails of the treadmill. Locate the clip attached to the key and slide it onto your waistband. Next, insert the key fully into the console as shown. After a moment, the displays will light. Note: When you are familiar with the console, you may go directly to step 4 if desired. The first time you use the console, please follow all steps.

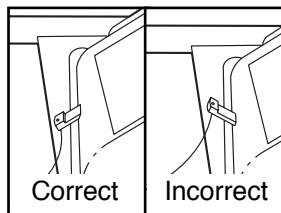

3 Select the MANUAL mode.

When the key is inserted, the MANUAL mode will be selected. If a different program has been selected, press the PROGRAM SELECT button repeatedly until a "P-1" appears in the TIME/PACE display (program 1 is the MANUAL mode).

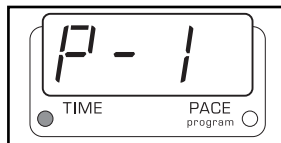

4 Press the START/ENTER button or the SPEED "+" button to start the walking belt.

After the button is pressed, there will be a brief pause; the walking belt will then begin to move at 1.0 mph. Hold the handrails and begin walking.

As you exercise, change the speed of the walking belt as desired by pressing the SPEED buttons. Each time one of the buttons is

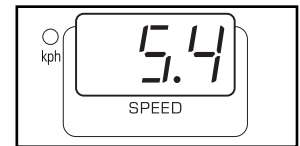

pressed, the speed will change by 0.1 mile per hour (mph). The buttons can be held down to change the speed quickly. The speed range is 0.5 mph to 10 mph. Note: When the SPEED buttons are pressed, the SPEED display will show the selected speed setting for six seconds. The display will then show the actual speed of the walking belt.

To stop the walking belt momentarily, press the STOP button. The displays will pause and the TIME/PACE display will begin to flash. To restart the walking belt, press the START/ENTER button or the SPEED "+" button. To stop the walking belt and reset the displays, hold down the STOP button for two seconds.

5 Change the incline of the treadmill if desired.

To change the incline of the treadmill, press the INCLINE buttons. Each time one of the buttons is pressed, the incline will change by 0.5%. The buttons can be held down to change the incline quickly. The incline range is 1.5% to 10%. The incline setting is shown in the INCLINE/DISTANCE display.

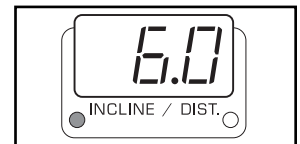

Note: After the INCLINE buttons are pressed, it may take a few seconds for the treadmill to reach the selected incline setting. **When you are finished exercising, change the incline of the treadmill to 1.5%. The incline must be at 1.5% before the treadmill is folded to the storage position or the treadmill may be damaged.**

6 Follow your progress with the four displays.

PULSE/CALORIES display

This display shows the your heart rate* and the approximate number of calories you have burned during your workout. The display will change from one number to the other every seven seconds. Indicators below the display will show which number is currently shown.



***For your heart rate to be shown, you must wear the optional CardioTrack™ heart rate monitor.**

TIME/PACE display

This display shows the total time that the walking belt has been moving and your current pace (pace is measured in minutes per mile). The display will change from one number to the other every seven seconds. Indicators below the display will show which number is currently shown. Note: When an INCLINE program is selected, the display will show the time remaining in the program rather than the elapsed time.

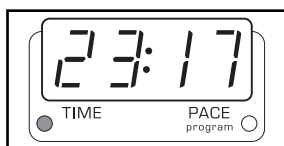

SPEED display

This display shows the current speed of the walking belt. Note: When the SPEED buttons are pressed, the display will show the selected speed setting for six seconds. The display will then show the actual speed of the walking belt.

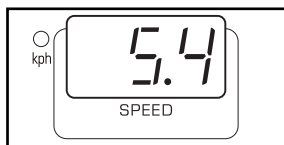

Note: The speed can be shown in either miles per hour (mph) or kilometers per hour (kph). The KPH indicator beside the SPEED display will light when the speed is shown in kph. To change the unit of

measurement, first hold down the START/ENTER button while inserting the key into the console. An "E" for english (miles) or an "M" for metric (kilometers) will appear in the PULSE/CALORIES display. Press the SPEED "+" button to change the unit of measurement. Remove and then reinsert the key.

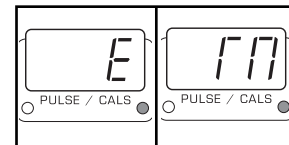

INCLINE/DISTANCE display

This display shows the distance that the walking belt has moved and the current incline level of the treadmill. Every seven seconds, the display will change from one number to the other. Indicators below the display will show which number is currently shown.

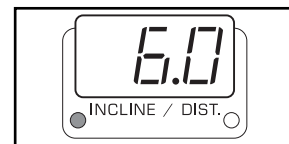

Note: When the INCLINE buttons are pressed, the display will change to show the selected incline setting. If the KPH indicator beside the SPEED display is dark, the distance will be displayed in miles. If the KPH indicator is lit, the distance will be displayed in kilometers.

7 When you are finished exercising, stop the walking belt and remove the key.

Step onto the foot rails and press the STOP button. **Change the incline of the treadmill to 1.5%. The incline must be at 1.5% before the treadmill is folded to the storage position or the treadmill may be damaged.**

Next, remove the key from the console. Store the key in a secure place. In addition, press the on/off switch to the off position. (See the drawing near the top of page 9.)

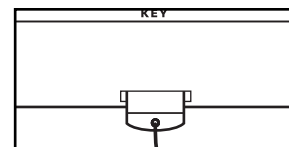

HOW TO USE THE INCLINE PROGRAMS

The three INCLINE programs automatically control the incline of the treadmill during your workouts. The graphs labeled P2, P3, and P4 on the console show how the incline will change during the HIKER, AEROBIC CROSS TRAINER, and INTERVAL programs. Follow the steps below to use an INCLINE program.

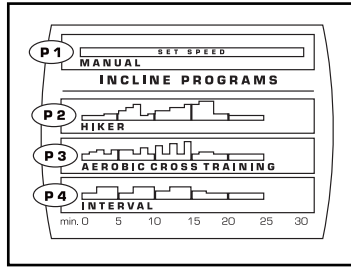

1 Plug in the power cord.

See step 1 on page 9.

2 Insert the key fully into the console.

See step 2 on page 9.

3 Select one of the INCLINE programs.

When the key is inserted, the MANUAL mode will be selected. To select one of the INCLINE programs, press the PROGRAM SELECT button repeatedly until a “P-2,” “P-3,” or “P-4” appears in the TIME/PACE display. (Program 2 is the HIKER program; Program 3 is the AEROBIC CROSS TRAINER program; Program 4 is the INTERVAL program.)

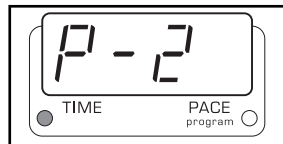

4 Press the START/ENTER button or the SPEED “+” button to start the program.

When the button is pressed, the SPEED display will flash and a tone will sound twice. If the incline of the treadmill is higher than 1.5%, it will automatically decrease to 1.5%. After a moment, the walking belt will begin to move at 1.0 mph. Hold the handrails and begin walking.

As you exercise, the incline of the treadmill will periodically change as indicated by the graphs labeled P2, P3, and P4 on the console. The speed of the walking belt can be changed as desired during the program with the SPEED buttons. The TIME/PACE display will show the time remaining in the program. During the last three minutes of the program, the walking belt will slow to allow you to cool down. During the last ten seconds of the program, the incline will decrease to 1.5%. When no time remains, the walking belt will slow to a stop.

To stop the program momentarily, press the STOP button. The displays will pause and the TIME/PACE display will begin to flash. To restart the program, press the START/ENTER button or the SPEED “+” button. To end the program, hold down the STOP button for two seconds.

Note: While the program is in progress, the difficulty level of the program can be adjusted, if desired, with the INCLINE buttons. Press the INCLINE “+” button. A number will flash in the INCLINE/DISTANCE display for three seconds. This number is the maximum incline that the treadmill will reach during the program. Press the INCLINE “+” button again. Each time the button is pressed, the maximum incline setting and all other incline settings of the program will increase slightly. The INCLINE “-” button can be used in the same way to decrease the difficulty level of the program.

5 Follow your progress with the four displays.

See step 6 on page 10.

6 When the program is completed, remove the key from the console.

Make sure that the incline of the treadmill is set at 1.5%. Remove the key from the console. Store the key in a secure place. In addition, press the on/off switch to the off position. (See the drawing near the top of page 9.)

Notes

How to Fold and Move the Treadmill

HOW TO FOLD THE TREADMILL FOR STORAGE

Before folding the treadmill, adjust the incline to the lowest position. Next, unplug the power cord. **Caution: You must be able to safely lift 45 pounds (20 kg) in order to raise, lower, or move the treadmill.**

1. Hold the treadmill with your hands in the locations shown at the right. **To decrease the possibility of injury, bend your legs and keep your back straight. As you raise the treadmill, make sure to lift with your legs rather than your back.** Raise the treadmill halfway to the vertical position.

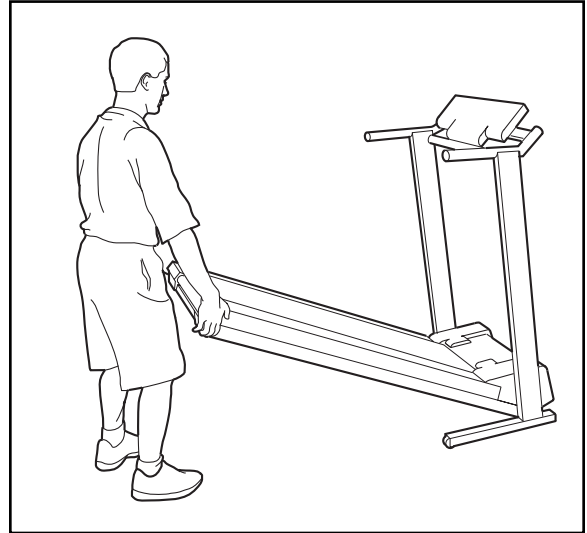

2. Move your right hand to the position shown and hold the treadmill firmly. Raise the treadmill until the frame passes the storage latch. **Make sure that the storage latch is inserted into the slot in the side of the frame.**

To protect the floor or carpet from damage, place a mat under the treadmill. Keep the treadmill out of direct sunlight. Do not leave the treadmill in the storage position in temperatures above 85° Fahrenheit.

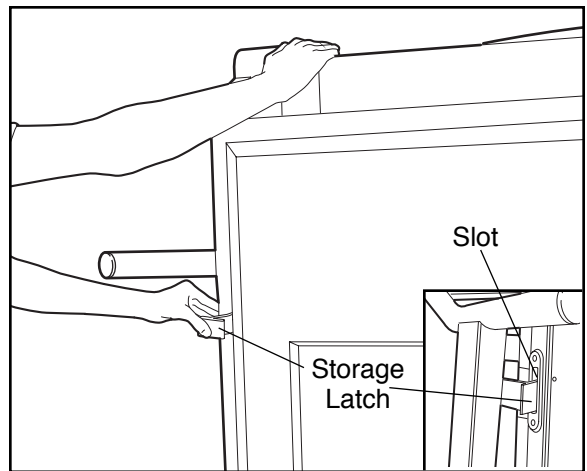

HOW TO MOVE THE TREADMILL

Before moving the treadmill, convert the treadmill to the storage position as described above. **Make sure that the storage latch is inserted into the slot in the side of the frame.**

1. Hold the handrails of the treadmill as shown. Place one foot on the base in the indicated location.
2. Tilt the treadmill back until it rolls freely on the front wheels. Carefully move the treadmill to the desired location. **Never move the treadmill without tipping it back, or the base pads may come off. To reduce the risk of injury, use extreme caution while moving the treadmill. Do not attempt to move the treadmill over an uneven surface.**
3. Place one foot on the base, and carefully lower the treadmill until it is resting in the storage position.



HOW TO LOWER THE TREADMILL FOR USE

1. Hold the upper end of the treadmill with your right hand as shown. Using your left thumb, press the storage latch to the left. Pivot the treadmill until the frame and foot rails are past the storage latch.

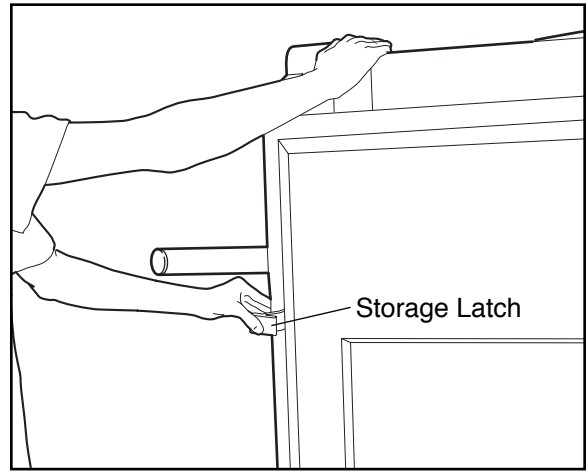

2. Hold the treadmill firmly with both hands, and lower the treadmill to the floor. **To decrease the possibility of injury, bend your legs and keep your back straight.**

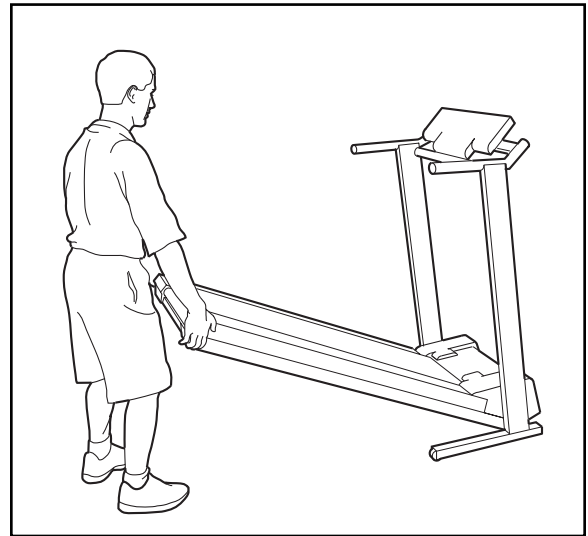

Maintenance and Trouble-shooting

Most treadmill problems can be solved by following the steps below. Find the symptom that applies, and follow the steps listed.

If further assistance is needed, please contact our Customer Service Department.

1. SYMPTOM: THE POWER DOES NOT TURN ON

- Make sure that the power cord is plugged into a surge protector, and that the surge protector is plugged into a properly grounded outlet. (See How to Plug in the Power Cord on page 7.) Use only a UL-listed surge protector, rated at 15 amps, with a 14-gauge cord of five feet or less in length. If using a surge protector with a power switch, make sure that the power switch is in the “on” position.
- After the power cord has been plugged in, make sure that the key is fully inserted into the console. (See step 2 on page 9.)
- Check the circuit breaker located on the treadmill near the power cord. If the switch protrudes as shown, the circuit breaker has tripped. To reset the circuit breaker, wait for five minutes and then press the switch back in.
- Check the on/off switch located at the front of the treadmill near the power cord. The switch must be in the “on” position.

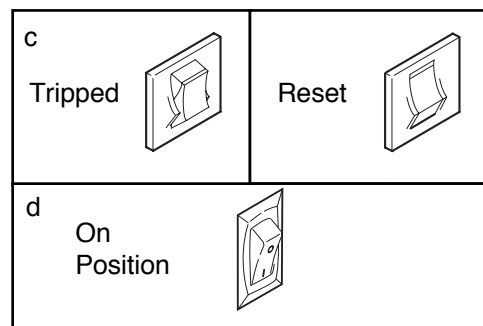

2. SYMPTOM: THE POWER TURNS OFF DURING USE

- Check the circuit breaker located on the treadmill frame near the power cord (see 1. c. above). If the circuit breaker has tripped, wait for five minutes and then press the switch back in.
- Check to make sure that the on/off switch is in the on position. (See 1. d. above.)
- Make sure that the power cord is plugged in.
- Remove the key from the console. Reinsert the key fully into the console. (See step 2 on page 9.)
- If the treadmill still will not run, please call our Customer Service Department.

3. SYMPTOM: AN ERROR CODE (“E1” OR “E6”) APPEARS ON THE CONSOLE

- If the console detects an incline error, an “E6” may appear in the INCLINE/DISTANCE display when the INCLINE buttons are pressed, and when the display shows the current incline level. If this error code appears, remove the key from the console, wait for ten seconds, and then reinsert the key. If the error code appears again, call our Customer Service Department. **Do not operate the treadmill until the problem is corrected.**
- If the console detects a speed error (no speed signal, an erratic speed signal, etc.), an “E1” may appear in the SPEED display. If this error codes appears, remove the key from the console, wait for ten seconds, and then reinsert the key. If the error code appears again, call our Customer Service Department. **Do not operate the treadmill until the problem is corrected.**

4. SYMPTOM: THE WALKING BELT IS OFF-CENTER WHEN WALKED ON

a. If the walking belt has shifted to the left, first remove the key and **UNPLUG THE POWER CORD**. Using the included allen wrench, turn the left rear roller adjustment bolt clockwise, and the right bolt counterclockwise, 1/4 of a turn each. Be careful not to overtighten the walking belt. Plug in the power cord, insert the key and run the treadmill for a few minutes. Repeat until the walking belt is centered.

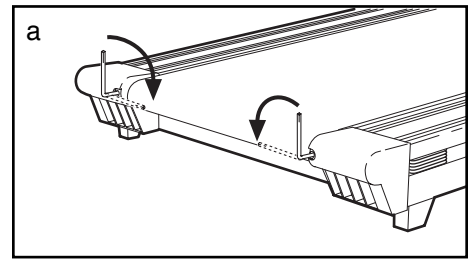

b. If the walking belt has shifted to the right, first remove the key and **UNPLUG THE POWER CORD**. Using the allen wrench, turn the left rear roller adjustment bolt counterclockwise, and the right bolt clockwise, 1/4 of a turn each. Be careful not to overtighten the walking belt. Plug in the power cord, insert the key and run the treadmill for a few minutes. Repeat until the walking belt is centered.

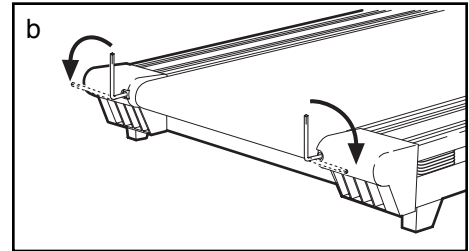

c. If the walking belt slips when walked on, first remove the key and **UNPLUG THE POWER CORD**. Using the allen wrench, turn both rear roller adjustment bolts clockwise, 1/4 of a turn. When the walking belt is correctly tightened, you should be able to lift **the edges** of the walking belt 3 to 4 inches off the walking platform. Be careful to keep the walking belt centered. Plug in the power cord, insert the key and run the treadmill for a few minutes. Repeat until the walking belt is properly tightened.

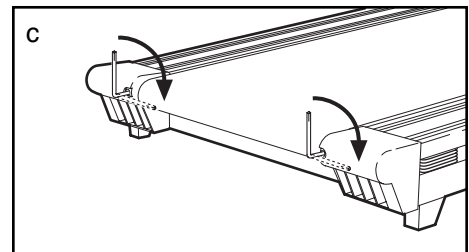

5. SYMPTOM: THE WALKING BELT SLOWS WHEN WALKED ON

a. Use only a UL-listed surge protector, rated at 15 amps, with a 14-gauge cord of five feet or less in length.

b. If the walking belt is overtightened, treadmill performance may decrease and the walking belt may be permanently damaged. Remove the key and **UNPLUG THE POWER CORD**. Using the allen wrench, turn both rear roller adjustment bolts counterclockwise, 1/4 of a turn. When the walking belt is correctly tightened, you should be able to lift **the edges** of the walking belt 3 to 4 inches off the walking platform. Be careful to keep the walking belt centered. Plug in the power cord, insert the key and run the treadmill for a few minutes. Repeat until the walking belt is properly tightened.

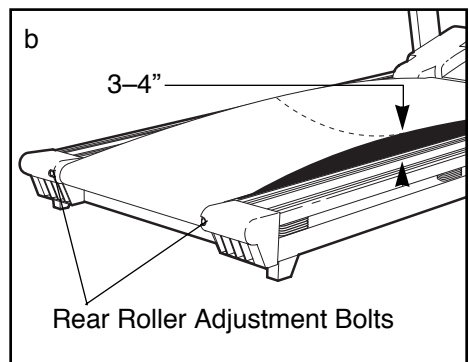

c. If the walking belt still slows when walked on, please contact our Customer Service Department.

6. SYMPTOM: THE DISPLAYS OF THE CONSOLE DO NOT FUNCTION PROPERLY

- a. Remove the key and **unplug the power cord**. Remove the screws from the hood. Carefully remove the hood. Locate the Reed Switch (74) and the Magnet (95) on the left side of the Pulley (17). Turn the Pulley until the Magnet is aligned with the Reed Switch. **Make sure that there is a 1/8" gap between the Magnet and the Reed Switch.** If necessary, loosen the Screw (90) and move the Reed Switch slightly. Retighten the Screw. Re-attach the hood, and run the treadmill for a few minutes to check for a correct speed reading.

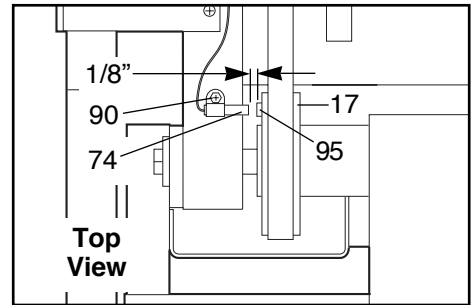

Conditioning Guidelines

FACTORS IN A SENSIBLE DIET

- Choose high-fiber, low-fat, and low-in-sugar foods: fruits, vegetables, and whole grains.
- Eat at least five servings of fruits and vegetables each day.
- Cut back on red meat consumption; eat lean meat, white meat, and fish.
- Choose healthy snacks; bring healthy foods with you to work or in the car.
- Eat regular meals or mini-meals. Control your portion size—don't binge or overeat. Eat slowly.
- Reduce fast food and pre-packaged meals.
- Pay attention to fat content and calories.
- Limit alcoholic beverages and caffeine.
- Drink at least eight to ten glasses of water a day.

EXERCISE STEPS

The following nine steps for designing your exercise program were developed by exercise physiologists at NordicTrack. The actual exercise you perform is only a part of a safe and effective training program. There are many other aspects to developing a life-long commitment to physical fitness.

1 Consult your physician before beginning any exercise program.

A medical examination or consultation with your physician is essential.

2 Establish personal fitness goals.

Set attainable, realistic goals. Reward yourself when you meet those goals. Remember, your goals should act as a guide for your workout program.

3 Determine your target heart rate.

Your target heart rate (THR), is the rate at which you would like your heart to work during aerobic exercise. It is expressed as a percentage of your maximum heart rate (MHR). MHR is the maximum number of times that your heart can pump during one minute. To determine your approximate MHR, subtract your age (in years) from 220. This is only an estimation of your MHR—only clinical stress testing can provide an actual MHR reading.

Once you have determined your MHR, you can establish your target heart rate zone. Beginning exercisers may wish to start at 60 to 70 percent of their MHR. This level is called the Health level. Exercise at 70 to 85 percent of your MHR for the optimal training, aerobic, or cardiovascular level—the Fitness level. Advanced exercisers, or those wishing to do sports, athletic conditioning, or interval training workouts should exercise at 80 to 85 percent of the MHR for short periods of time. The chart below shows Target Heart Rate Zones for Health, Fitness, and Advanced exercisers.

Be sure to check your heart rate at least twice during an aerobic conditioning session. First, check your heart rate five minutes into your workout to be sure that you are at the proper intensity. Then, check it again near the end of your workout to verify that you have maintained your target heart rate for the recommended period of time.

TARGET HEART RATE ZONES

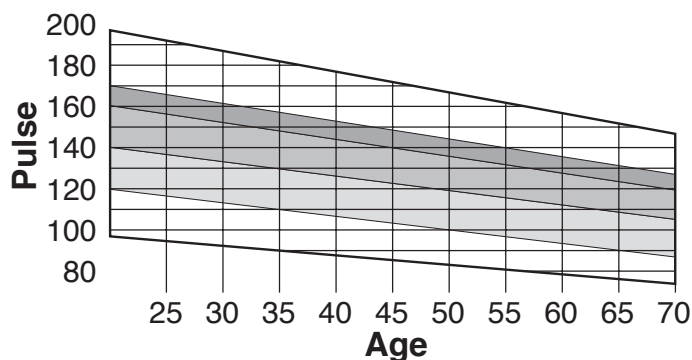

Health	Fitness	Advanced
Beginner, low-intensity + long duration = fat burning	Optimal training, aerobic or cardiovascular	Sports, athletic conditioning, interval training

WEIGHT LOSS TIPS

At least four, 30-minute workouts per week, along with a reduced-calorie diet, are recommended if you are trying to lose weight. However, be sure to stay within your target heart rate zone and exercise a maximum of 5 days per week for 60 minutes per workout.

Good posture is the key to safe, comfortable workouts. Keep your chin up and your head facing forward. Align your head and shoulders with your hips. Avoid leaning forward. Keep your back straight.

4 Warm up before you begin.

A warm-up routine prepares your body and mind for vigorous exercise. It also provides insurance against injury and soreness. Warm up with two to five minutes of slow exercise, at minimal intensity.

5 Stretch after your warm-up.

A pliable, well-stretched muscle is less susceptible to injury. Perform the recommended stretches on a smooth, flat surface.

The correct form for several stretches is described below (refer to the drawings at the right). Be sure to move slowly as you stretch—never bounce.

1. Toe Touch Stretch—Sit with your knees bent slightly and slowly bend forward from your hips. Allow your back and shoulders to relax as you reach toward your toes as far as possible. Hold for 15 to 30 seconds, then relax. Repeat 3 times. Stretches: Hamstrings, back of knees, and back.

2. Calf/Achilles Stretch—With one leg in front of the other, reach forward and place your hands against a wall. Keep your back leg straight and your back foot flat on the floor. Bend your front leg, lean forward, and move your hips toward the wall. Hold for 15 to 30 seconds, then relax. Repeat 3 times for each leg. To cause further stretching of the achilles tendons, bend your back leg as well. Stretches: Calves, achilles tendons, and ankles.

3. Hamstring Stretch—Sit with one leg extended. Bring the sole of the opposite foot toward you and rest it against the inner thigh of your extended leg. Reach toward your toes as far as possible. Hold for 15 to 30 seconds, then relax. Repeat 3 times for both legs. Stretches: Hamstrings, lower back, and groin.

4. Inner Thigh Stretch—Sit with the soles of your feet together and your knees outward. Pull your feet toward your groin area as far as possible. Hold for 15 to 30 seconds, then relax. Repeat 3 times. Stretches: Quadriceps and hip muscles.

5. Quadriceps Stretch—With one hand against a wall for balance, reach back and grasp one foot with your other hand. Bring your heel as close to your buttocks as possible. Hold for 15 to 30 seconds, then relax. Repeat 3 times for each leg. Stretches: Quadriceps and hip muscles.

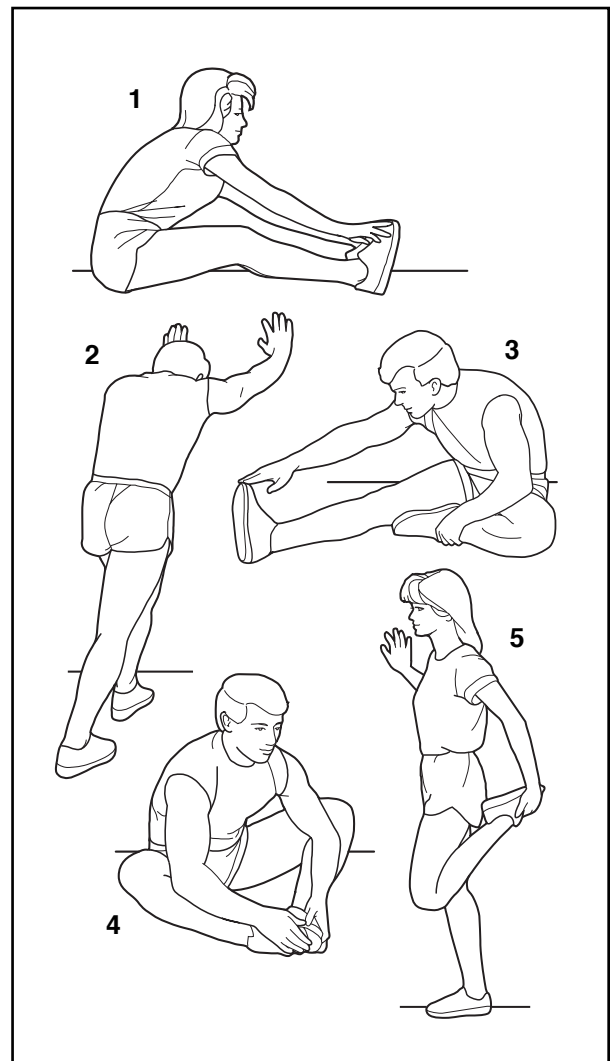

BENEFITS OF AEROBIC EXERCISE

- Effective weight loss and management
- Added protection from heart disease
- Increased strength and health of bones
- Higher levels of energy for greater productivity during the day
- Healthy stress relief from a pressure-packed day
- Greater intellectual capacity and productivity

6 Get FIT with the PowerTread 1500.

Effective aerobic exercise has three major parts: frequency, intensity, and time. The acronym "FIT" may help you to remember these three parts:

F "F" stands for the frequency of your workouts. Three to five workouts per week are recommended. Exercise at least four times a week for weight loss.

I "I" refers to the intensity of your workout. Check your heart rate at least twice during your aerobic exercise session: once during the session and once again at the end. Maintain a workout intensity level within your Target Heart Rate Zone. You can measure your heart rate using the method described below:

1. Lower your wrist below your heart level. This will make your heart rate stronger and easier to feel.

2. Using the index and middle fingertips of your right hand, touch your left wrist, one-fourth inch from your wrist joint, at the base of your thumb.

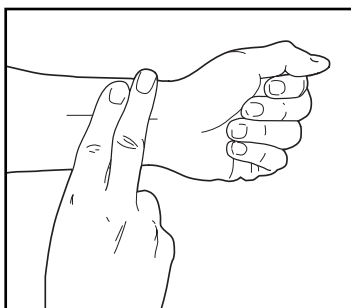

3. Apply minimal pressure with both fingers—let the beat come to your fingers. If you can't find your pulse, use the opposite wrist and hand.

T "T" is for the time or duration of your workout. Beginning exercisers may wish to start with 5 to 10 minutes of aerobic activity. Those in average physical condition should exercise for 20 to 30 minutes. Highly fit people, or people who want to lose weight, should exercise for 30 to 60 minutes. The key to the time factor is that you maintain your target heart rate for the duration of the workout period.

Remember to take it slowly. Fitness is a lifelong commitment. If you can't go the full 20 minutes from the start, which is common, try to exercise for five minutes at a time, a couple of times a day. Recent research indicates that several short workouts in one day can also provide fitness benefits. Gradually, your stamina will increase and it will become easier to exercise for longer periods of time.

7 Cool down after aerobic exercise.

Keep moving! It is important that you cool down properly to allow your heart rate to decrease slowly after it has been elevated. This helps the blood flow from your extremities back to your heart. Keep your legs moving on the treadmill at a slower pace for at least five minutes following the aerobic phase.

8 Stretch again at the end of your exercise session.

Stretching after exercise reduces muscle soreness. See step 5 on page 19.

9 Participate in strength training.

"Balanced fitness, including both strength training and aerobic exercise, can do more to ensure a happy life than just about anything else known to medical science today."

—Kenneth Cooper, M.D., M.P.H., founder of The Cooper Institute For Aerobic Research, Dallas, Texas.

A strength-training program increases your lean muscle mass. Lean muscle mass aids in burning body fat. With additional muscle mass and strength, you will receive the full benefits of an exercise program. You will also be less prone to injuries during the aerobic phase of your workout.

WORKOUT TIPS

Full-body conditioning helps take care of many of life's aches and pains. However, it takes time for your body to adapt to any new routine. Below are some tips that will help ease you into your new NordicTrack routine.

- Begin and end each exercise session with the stretches on page 19. Stretch in a smooth, controlled manner. Hold each stretch for 15 to 30 seconds. You may experience some initial muscle soreness and discomfort as a result of exercising inactive or poorly stretched muscles. For maximum benefit, a stretching routine must be performed every day.
- Be aware of your body's signals and react to them accordingly. At your correct exercise intensity, you should be able to whistle or maintain a normal conversation. If during exercise you feel tired, light-headed, dizzy, or nauseated, stop exercising immediately and consult your physician. Your heart rate may also be affected by such things as stress, caffeine, nicotine or prescription drugs.

WORKOUT PROGRAMS

The Health level typically lasts four to six weeks. At this level you should be concerned with slowly improving your fitness level and endurance.

Take it slowly. Set mini-goals for yourself. You may want to begin your fitness routine with three or four short, 5- or 10-minute workouts in a day.

Move on to the Fitness Level only when you feel ready and your heart rate has moved below your target heart rate zone.

The Fitness level usually lasts 12 to 20 weeks. (It may last longer, depending on your fitness goals.) At this level you should strive to achieve your fitness goals.

Set realistic short- and long-term goals for yourself. Frequently re-evaluate your fitness goals and reward yourself as you are successful.

Move on to the Advanced Level when you have reached your fitness goals and your heart rate has moved below your target heart rate zone.

Work out at the Advanced level once you have reached your desired fitness goals. It is intended to be a maintenance program and should continue on a regular, long-term basis.

You may wish to add Interval Training to your maintenance program as well. Interval training will add variety to your workout routine and further condition your cardiovascular system. Interval training has been shown to promote higher levels of aerobic conditioning. It consists of spurts of high-intensity activity followed by active rest periods of exercise at a lower intensity. For example, a one-minute spurt of high-resistance, fast exercise* is followed by a two- to three-minute active rest period of low-resistance, slow exercise. The duration of these periods should be based more on how you feel rather than time. A sequence such as this should be repeated 5 to 20 times during your workout session.

*Estimated maximum heart rate (MHR) = 220 – your age.

Heart Rate Intensity

HEART RATE INTENSITY	Age	20	30	40	50	60	70	80
60% - 70% HEALTH	b.p.m.	120-140	114-133	108-126	102-119	96-112	90-105	84-98
70% - 85% FITNESS	b.p.m.	140-170	133-162	126-153	119-145	112-136	105-128	98-119
80% - 85% ADVANCED	b.p.m.	160-170	152-162	144-153	136-145	128-136	120-128	112-119

Part List—Model No. NTTL90081

R0299A

To find the parts listed below, refer to the Exploded Drawing attached in the center of this owner's guide.

Key No.	Qty.	Description	Key No.	Qty.	Description
1	2	Rear Roller Adj. Bolt	50	1	Belly Pan
2	1	Front Roller Adj. Bolt	51	4	Plastic Stand-Off
3	2	Rear Roller Guard	52	1	Wire Harness
4	1	On/Off Switch	53	2	Rear Pad
5	1	Storage Latch	54	1	Left Rear Endcap
6	4	Isolator	55	1	Sensor Star Washer
7	2	Ground Wire Screw	56	4	Frame Pivot Bolt
8	6	Platform Screw	57	1	Console Wire Harness
9	1	Left Foot Rail	58	1	Right Foot Rail
10	4	Handrail Endcap	59	1	Rubber Washer
11	1	Reed Switch Clip	60	1	Incline Motor Spacer
12	4	Wire Clip	61	2	Sensor Locknut
13	1	10" Pulse Wire	62	18	Belly Pan Fastener
14	4	Small Plug	63	1	Right Rear Endcap
15	1	Key/Clip	64	2	Base Endcap
16	1	Frame	65	1	Releaseable Wire Tie
17	1	Front Roller/Pulley	66	5	8" Wire Tie
18	1	Rear Roller	67	1	Wire Tie Holder
19	1	Incline Frame	68	2	Frame Endcap
20	1	Electronics Shield	69	1	Incline Disk
21	1	Incline Motor Shield	70	1	Upright/Base
22	2	Pivot Spacer	71	1	Motor
23	2	Side Hood Bracket	72	1	Pulley/Flywheel/Fan
24	8	Wheel Nut	73	1	Latch Catch
25	6	Incline Bolt/Motor Tension Bolt	74	1	Reed Switch/Sensor Wire
26	1	Incline Motor	75	2	Wheel Spacer
27	1	Controller	76	1	Photo Switch
28	1	Electronics Plate	77	1	8" Ground Wire
29	2	Rear Isolator	78	1	Console
30	2	Wheel	79	1	Shock
31	1	Power Cord	80	1	Walking Belt
32	1	Power Cord Grommet	81	1	Walking Platform
33	1	Front Hood Bracket	82	1	Incline Stop Bracket
34	1	Outlet Bracket	83	1	Latch Warning Decal
35	1	Circuit Breaker	84	1	Motor Hood
36	4	Rear Platform Screw	85	1	Incline Motor Plate
37	2	Wheel Bolt	86	4	Hood Screw
38	1	Front Belly Pan	87	1	Allen Wrench
39	1	Motor Pivot Bolt	88	1	Wrench Clip
40	1	Motor Pivot Nut	89	6	Base Pad
41*	1	Motor/Pulley/Flywheel/Fan	90	30	Small Screw
42	1	Motor Belt	91	4	Pad Screw
43	29	Screw	92	1	Power Supply
44	2	Endcap Plate	93	2	Latch Spacer
45	1	Motor Tension Washer	94	2	Foot Rail Track
46	2	Tension Star Washer	95	1	Magnet
47	2	Sensor Screw	96	2	Motor Tension Nut
48	2	Belt Guide	97	2	Incline Warning Decal
49	3	Roller Adjustment Washer	98	1	Front Roller Adj. Nut

Key No.	Qty.	Description	Key No.	Qty.	Description
#	1	8" Black Wire, 2 Female	#	1	8" Blue Wire, 2 Female
#	1	4" Black Wire, 2 Female	#	1	8" Green Wire, Ring/Female
#	1	8" Wire Harness	#	1	Owner's Guide
#	1	14" White Wire, 2 Female			

These parts are not illustrated.

* Includes all parts shown in the box.

Specifications are subject to change without notice.

Ordering Replacement Parts

To order replacement parts, call our Customer Service Department toll-free at 1-800-999-3756, Monday through Friday, 6 a.m. until 6 p.m. Mountain Time (excluding holidays). When ordering parts, please be prepared to give the following information:

- The MODEL NUMBER OF THE PRODUCT (NTTL90081).
- The NAME OF THE PRODUCT (NordicTrack PowerTread™ 1500).
- The SERIAL NUMBER OF THE PRODUCT (see the front cover of this manual).
- The KEY NUMBER AND DESCRIPTION OF THE PART(S) (see the EXPLODED DRAWING attached to the center of this manual, and the PART LIST on pages 22 and 23).

If possible, place the treadmill near your telephone for easy reference when calling.

Exploded Drawing — Model No. NTTL90081

R0299A

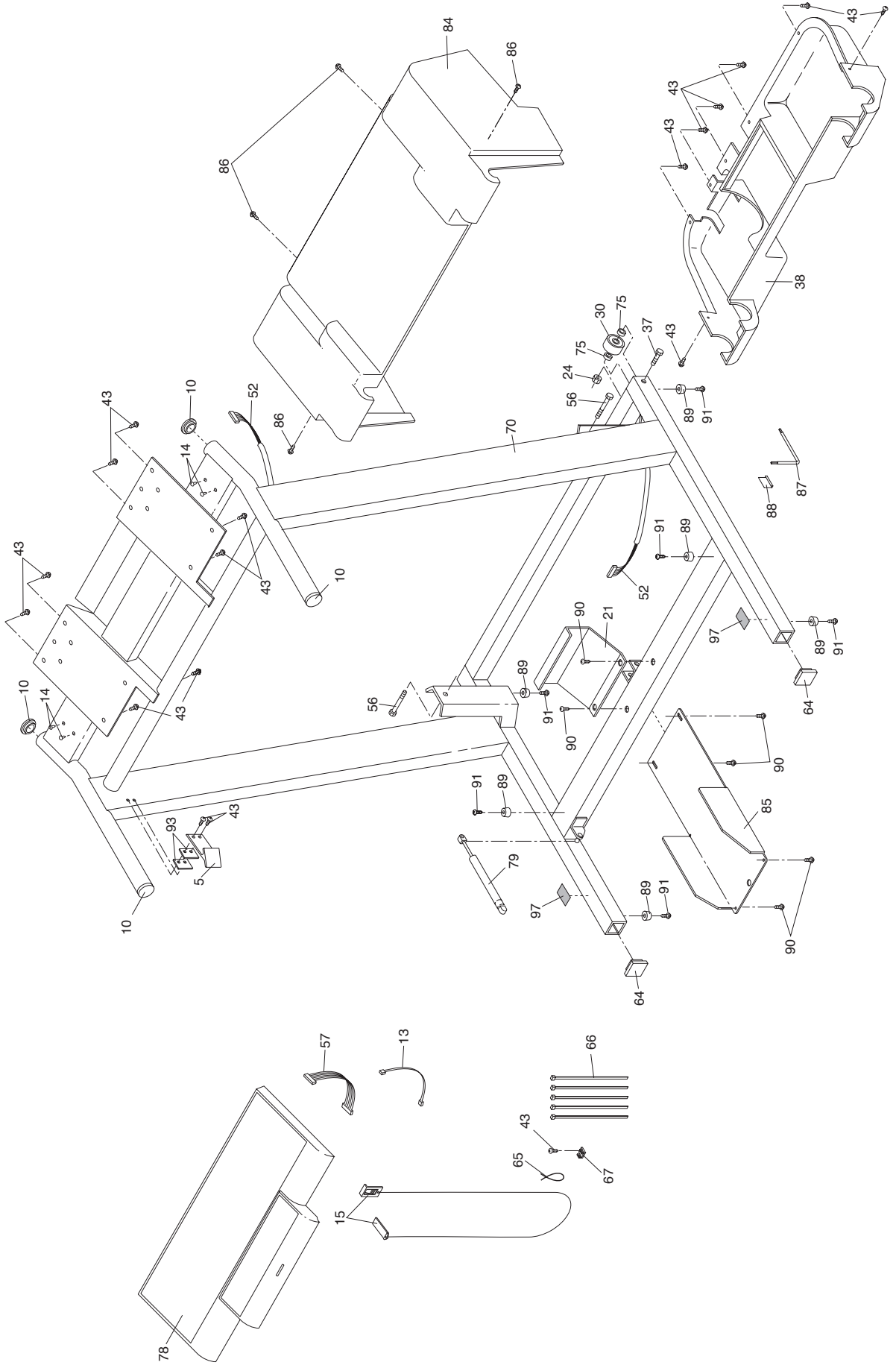

Exploded Drawing — Model No. NTTL90081

R0299A

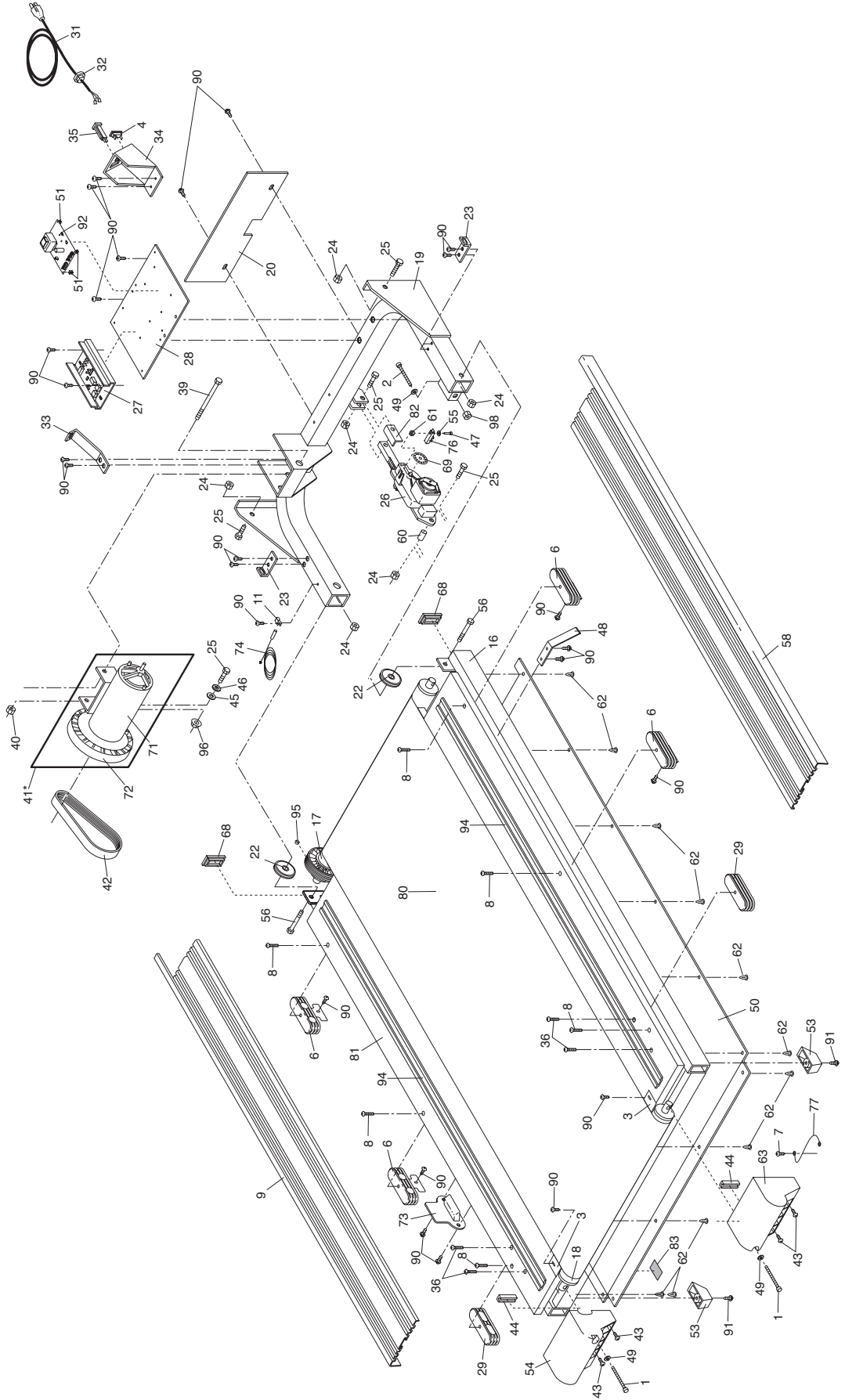

Limited Warranty

WHAT IS COVERED—The entire NordicTrack PowerTread™ 1500 (“Product”) is warranted to be free of all defects in material and workmanship.

WHO IS COVERED—The original purchaser or any person receiving the Product as a gift from the original purchaser.

HOW LONG IS IT COVERED—ICON Health & Fitness, Inc. (“ICON”), warrants the motor for three years after the date of purchase. All other parts are covered for two years after the date of purchase. Labor is covered for one year.

WHAT WE DO TO CORRECT COVERED DEFECTS—We will ship to you, without charge, any replacement part or component, providing the repairs are authorized by ICON first and are performed by an ICON trained and authorized service provider, or, at our option, we will replace the Product.

WHAT IS NOT COVERED—Any failures or damage caused by unauthorized service, misuse, accident, negligence, improper assembly or installation, alterations, modifications without our written authorization or by failure on your part to use, operate, and maintain as set out in your User’s Manual (“Manual”).

WHAT YOU MUST DO—Always retain proof of purchase, such as your bill of sale; store, operate, and maintain the Product as specified in the Manual; notify our Customer Service Department of any defect within 10 days after discovery of the defect; as instructed, return any defected part for replacement or, if necessary, the entire product, for repair.

USER’S MANUAL—It is VERY IMPORTANT THAT YOU READ THE MANUAL before operating the Product. Remember to do the periodic maintenance requirements specified in the Manual to assure proper operation and your continued satisfaction.

HOW TO GET PARTS AND SERVICE—Simply call our Customer Service Department at 1-800-999-3756 and tell them your name and address and the serial number of your Product. They will tell you how to get a part replaced, or if necessary, arrange for service where your Product is located or advise you how to ship the Product for service. Before shipping, always obtain a Return Authorization Number (RA No.) from our Customer Service Department; securely pack your Product (save the original shipping carton if possible); put the RA No. on the outside of the carton and insure the product. Include a letter explaining the product or problem and a copy of your proof of purchase if you believe the service is covered by warranty.

ICON is not responsible or liable for indirect, special or consequential damages arising out of or in connection with the use or performance of the product or damages with respect to any economic loss, loss of property, loss of revenues or profits, loss of enjoyment or use, costs of removal, installation or other consequential damages of whatsoever nature. Some states do not allow the exclusion or limitation of incidental or consequential damages. Accordingly, the above limitation may not apply to you.

The warranty extended hereunder is in lieu of any and all other warranties and any implied warranties of merchantability or fitness for a particular purpose is limited in its scope and duration to the terms set forth herein. Some states do not allow limitations on how long an implied warranty lasts. Accordingly, the above limitation may not apply to you.

No one is authorized to change, modify or extend the terms of this limited warranty.

This warranty gives you specific legal rights and you may have other rights which vary from state to state.

ICON HEALTH & FITNESS, INC., 1500 S. 1000 W., LOGAN, UT 84321-9813